

Abstract

The team designed and manufactured an aircraft set to compete in the annual AIAA DBF competition. The goal of the team was to design a plane which would be fast, lightweight, and able to carry large payloads. This was accomplished by using high-lift airfoil, a 14 lb-thrust motor, and the use of composite material. Recorded cruise speeds of 80 ft/s and a takeoff distance of only 4 feet are two of the many accomplishments of the team's design.



Customer Needs and Requirements

- Max take off distance is 20 feet
- Wingspan cannot exceed 5 feet
- Weight cannot exceed 55 pounds
- Parking Configuration cannot exceed 2.5 feet
- Max Battery Capacity is 100 W-h
- Assemble in 5 minutes

Mission 1 "Delivery"

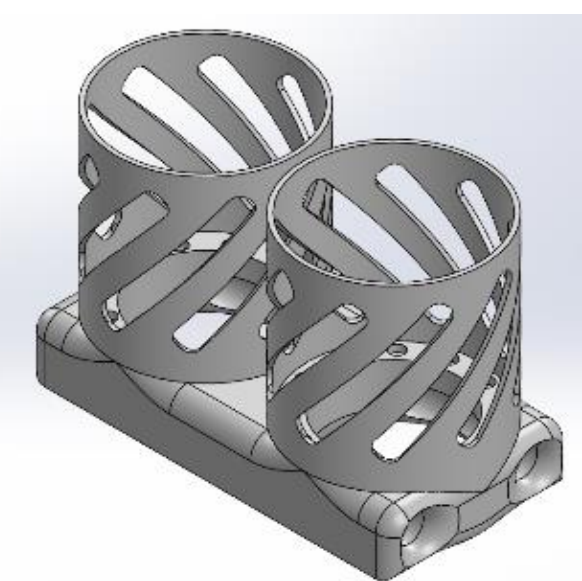

Mission 2 "Medical Transport"

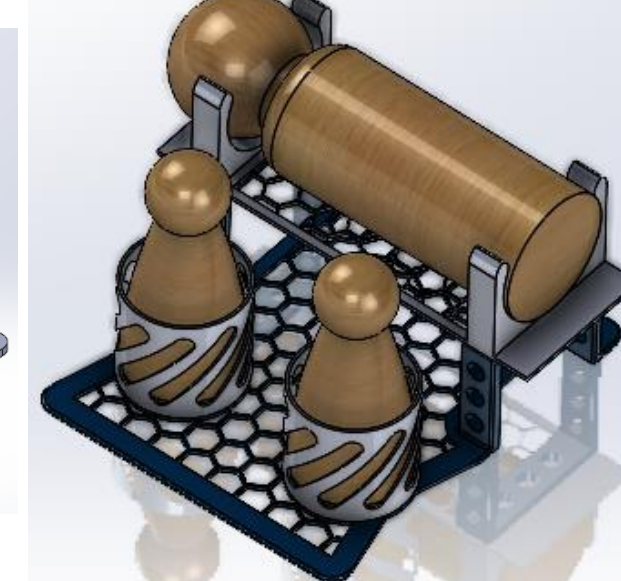
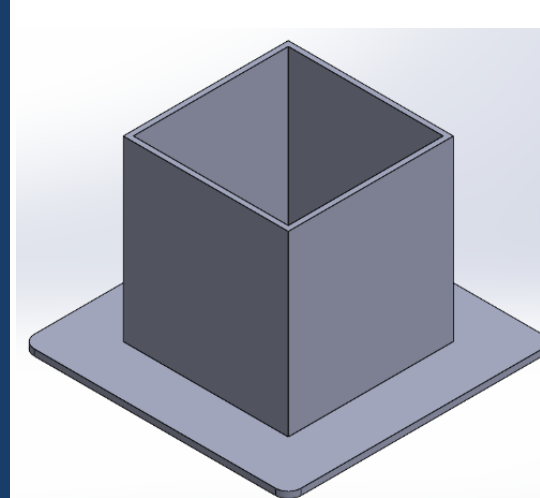

Mission 3 "Urban Taxi"



Concept Selection

- High Wing (Foam Core, Carbon Fiber Wrapped)
- S1223 Airfoil
- Bi-Fold Wing
- Rectangular Fuselage Shape (Semi-Monocoque Structure Wrapped in Carbon Fiber)
- Conventional Tail Configuration
- Vertical Opening Hinge Hatches
- Tricycle Landing Gear
- 17" propeller



Design Solution

MATLAB, OpenVSP and XFLR5 were used to size the aircraft. These software generated the optimal wing, tail and fuselage geometries based on aerodynamic principles and the competition regulations. ANSYS confirmed that these geometries would support the anticipated loads.

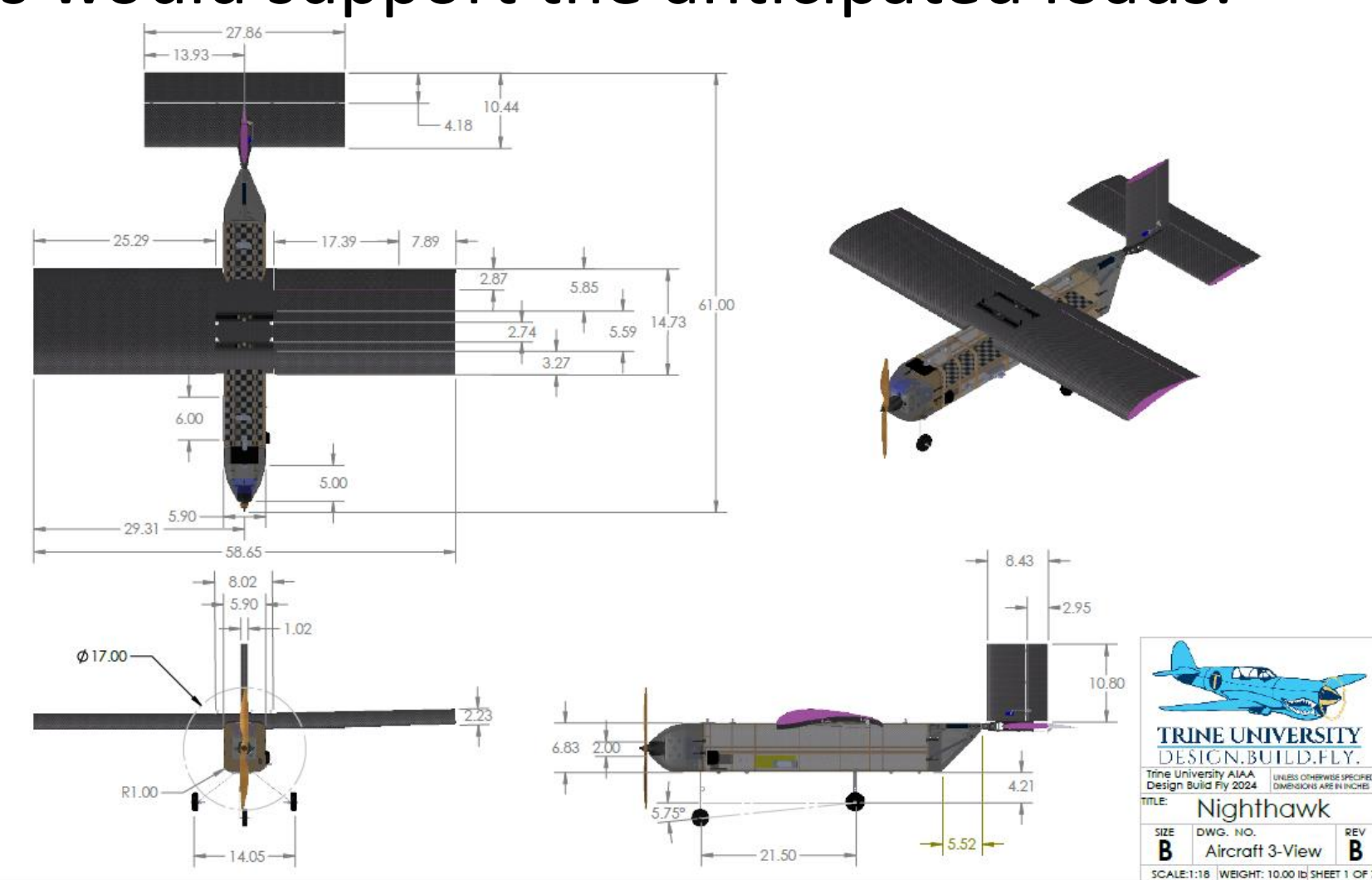

Fuselage



- Wooden dowels
- Laser cut plywood bulkheads and floor
- Monokote floor
- Cut landing gear and folding mechanism mounting blocks

Wing



- 3D print wing folding mechanism
- Hot wire foam into airfoil shape
- Epoxy carbon fiber to foam
- Connected with carbon fiber rods

Tail

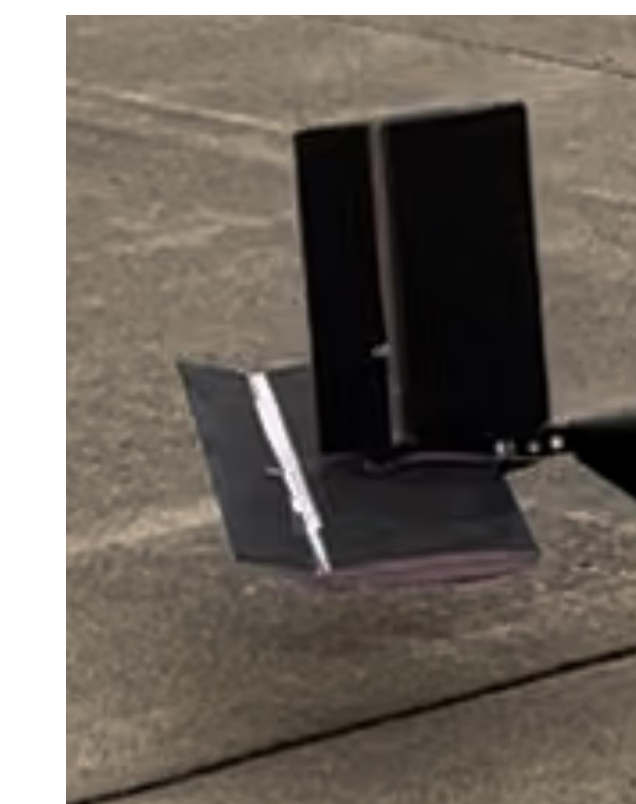

- 3D print tail connector
- Hot wire foam into airfoil shape
- Epoxy carbon fiber to foam
- Connected with carbon fiber rods

Assembly

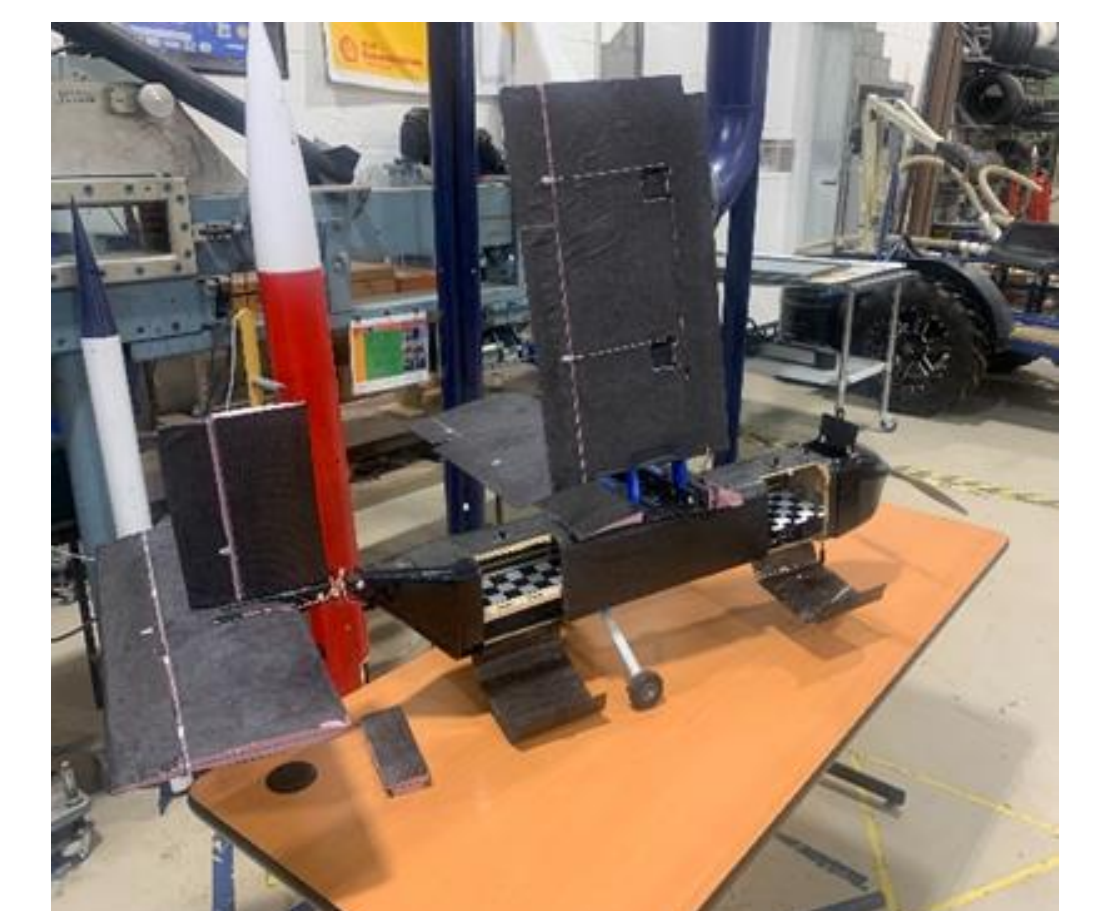

- Plane in parked position
- Plane in flight configuration

Testing and Validation

Prototype 1:

- Initial design
- Empty weight ~ 9.75 lb
- Takeoff Distance ~ 4 ft
- Issues with weak motor mount



Prototype 2:

- Improved aluminum motor mount
- Empty weight ~ 10.05 lb
- Takeoff Distance ~ 10 ft
- Issues with assembly mechanisms
- Double wheel front landing gear



Prototype 3:

- Empty weight ~ 10.2 lb
- Takeoff distance ~ 16 ft
- Latches and pins were added for ease of assembly
- Shocks added to front landing gear to absorb impact



Acknowledgments

We extend our gratitude to our advisors Dr. Chandrashekar, Dr. Canino, and Joe Thompson. Our team dedicated itself to creating the best design for competition, we recognize that without their guidance, we wouldn't have reached our current level of achievement.

We extend a special appreciation to our pilot, David Love, for generously volunteering his time and efforts. Additionally, we express gratitude to our donors Luke and Kim Roseboom, Rodney Hettler, Leslie Peterson, Nancy Thomas, Sue Johnson, Jeremy Rader, and Sue Zurface.

Furthermore, we extend our immense gratitude to Trine University for its resources, and to the Indiana Space Grant consortium for supplying majority of the funding required to make our project possible.