

ABSTRACT

Hendrickson is a leading manufacturer in suspension systems components for heavy trucks and the sponsor for the Metal Shavings Shredder project. The tube cutting process that Hendrickson uses, produces metal shavings that are a waste of time and space for the organization and dangerous to handle by hand (Figure 1). Hendrickson has the goal of limiting this with a metal shredder. The shredder will reduce the shavings to a much safer and manageable size for the operators and will save Hendrickson time and money in the long run being there will be less time and money spent ridding of the metal shavings. With this project being a continuation of a previous team, the current team was tasked with improving certain areas of the machine and getting the project to a functioning and safe state for Hendrickson. Figure 2 shows the beginning state of the machine for the team with a frame, shredding box, electrical box, motor, and gearbox.



Figure 1: Metal Shavings



Figure 2: Machines Starting State

CUSTOMER NEEDS/SPECS

Table 1 shows the requirements that were set by Hendrickson and were goals that the team kept in mind during the design process. These needs were set with the goal of reducing the shavings with a low initial cost in a safe and effective manner. These are different than that the previous teams as there were new goals for Hendrickson as the project progressed.

Table 1: Technical Requirements & Customer needs

Customer Needs	Technical Requirements
Toque Limiter	Incorporate Torque Limiter
Improved Safety	Safety Guarding, Proximity Sensors
Ease of Maintenance	Component replacement/removal
Hopper	New hopper that fits under shredder
Cost Effeciant	Less than \$9,000

DESIGN CONCEPTS

Various designs for the safety guarding and the motor/gearbox assembly mounts were presented to the sponsor and shown in Figures 3-6. The final designs chosen were a double-door design shredder shroud, two box shrouds, and sliding motor and gearbox mounts.

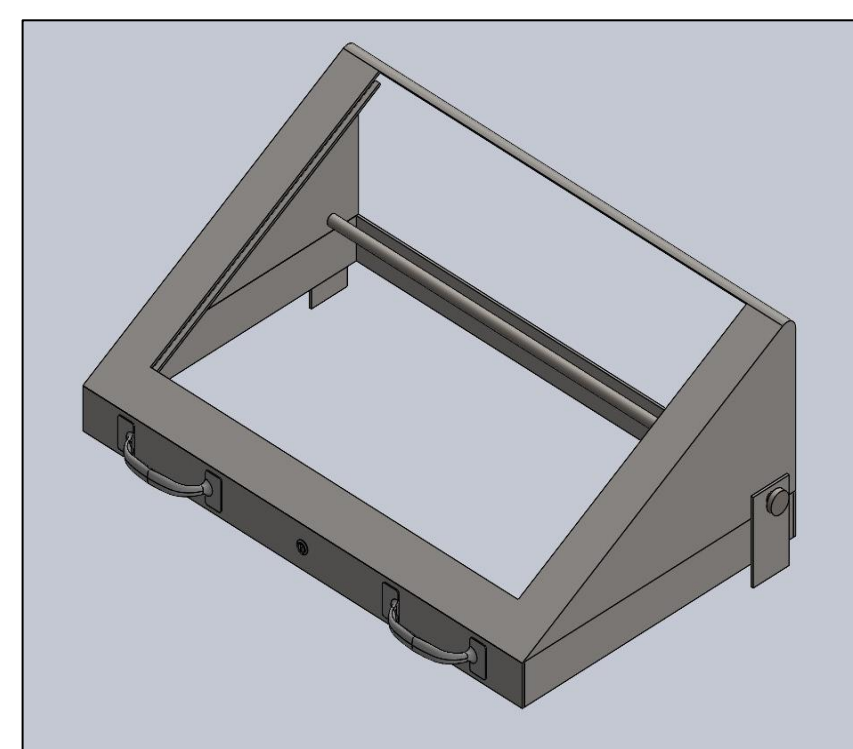

Figure 3: Rotating Hood Design Concept



Figure 4: Spindle Box w/ Door & Lock

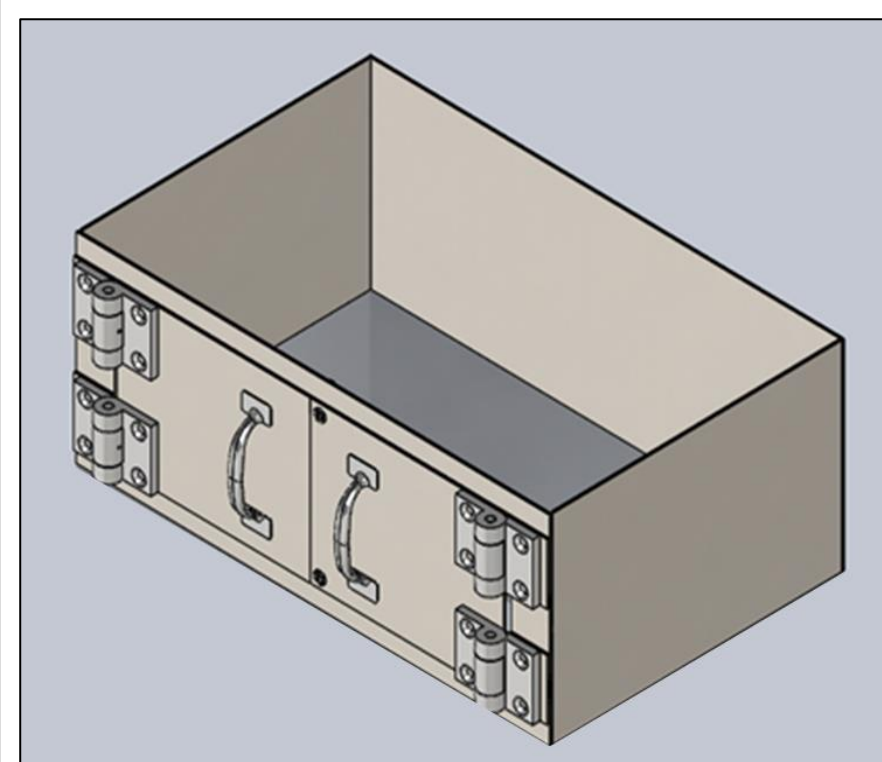

Figure 5: Selected Shredder Safety Guarding

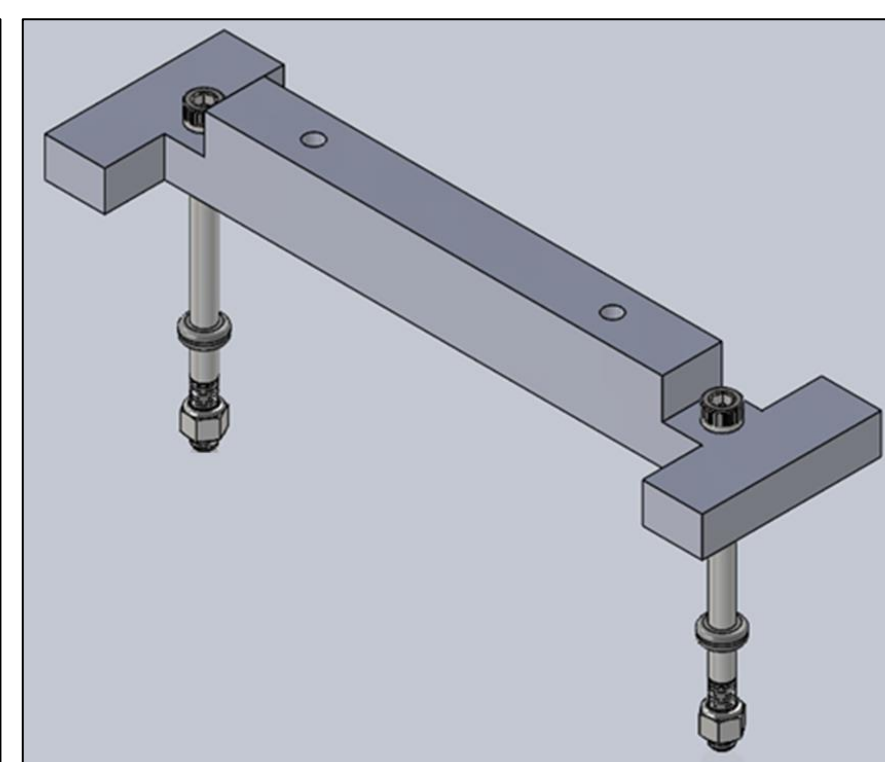

Figure 6: Mounts For Gearbox and Motor

FABRICATION

The fabrication, Figures 7-8, consisted of a variety of manufacturing processes to produce the designed components for the metal shredder. While some components were purchased like the torque limiter, fasteners, and couplings, other critical components or services like heat treatment were outsourced to local machine shops like Wauseon and Conley Welding. Other components were manufactured by the team using the resources on campus.

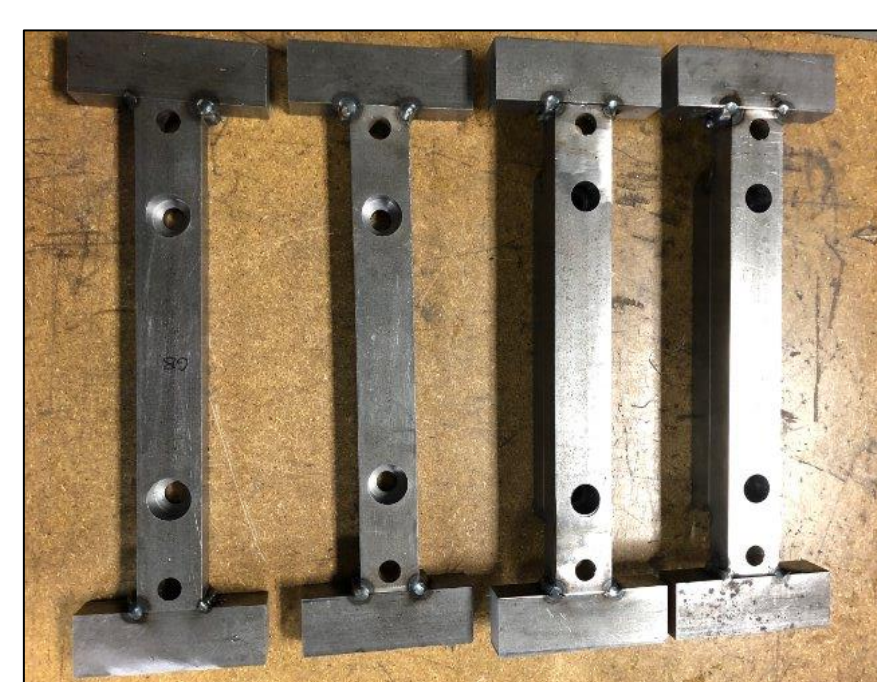

Figure 7: Mounts, DET Team



Figure 8: Spindle Box, Conley Welding

TEST RESULTS

Testing of the machine was done with the assistance of the team's sponsor, George Hoger, and the head of maintenance at Hendrickson, Dave Warner. The machine was wired up in the foundry and was powered up with a 480 V connection. For the team's initial test only the motor and the gearbox were hooked up to make sure that both ran properly. The testing was successful, and the motor and gearbox were proven to work the way the team had expected them to. Not only were these two key items proven to work, but the spacing between them for the safety guarding was also confirmed with the designed shrouds. The second test that the team performed was adding shavings to the shredding box. This proved a few design flaws in the spindle assembly such as a coupling as too weak and needed to be addressed.



Figure 9: Dave Warner Dry Running the Machine

FINAL DESIGN

The design team was successful in collaborating with Hendrickson to create a functioning, safe metal shavings shredder (Figs. 10-12). While the shredder lacks some safety precautions like proximity sensors and the machine to be controlled from the tube cutter's computer, all goals that Hendrickson set for the team and the metal shredder have been met. The final assembly is operational with a 480 V electrical connection and reduces metal shavings to a much safer and manageable size for operators.



Figure 10: Torque Limiter & Couplings Selected

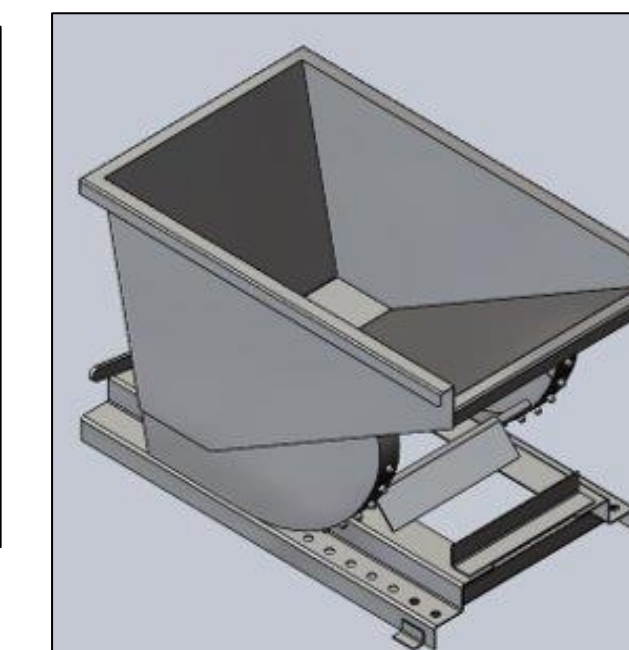

Figure 11: Hopper Selected

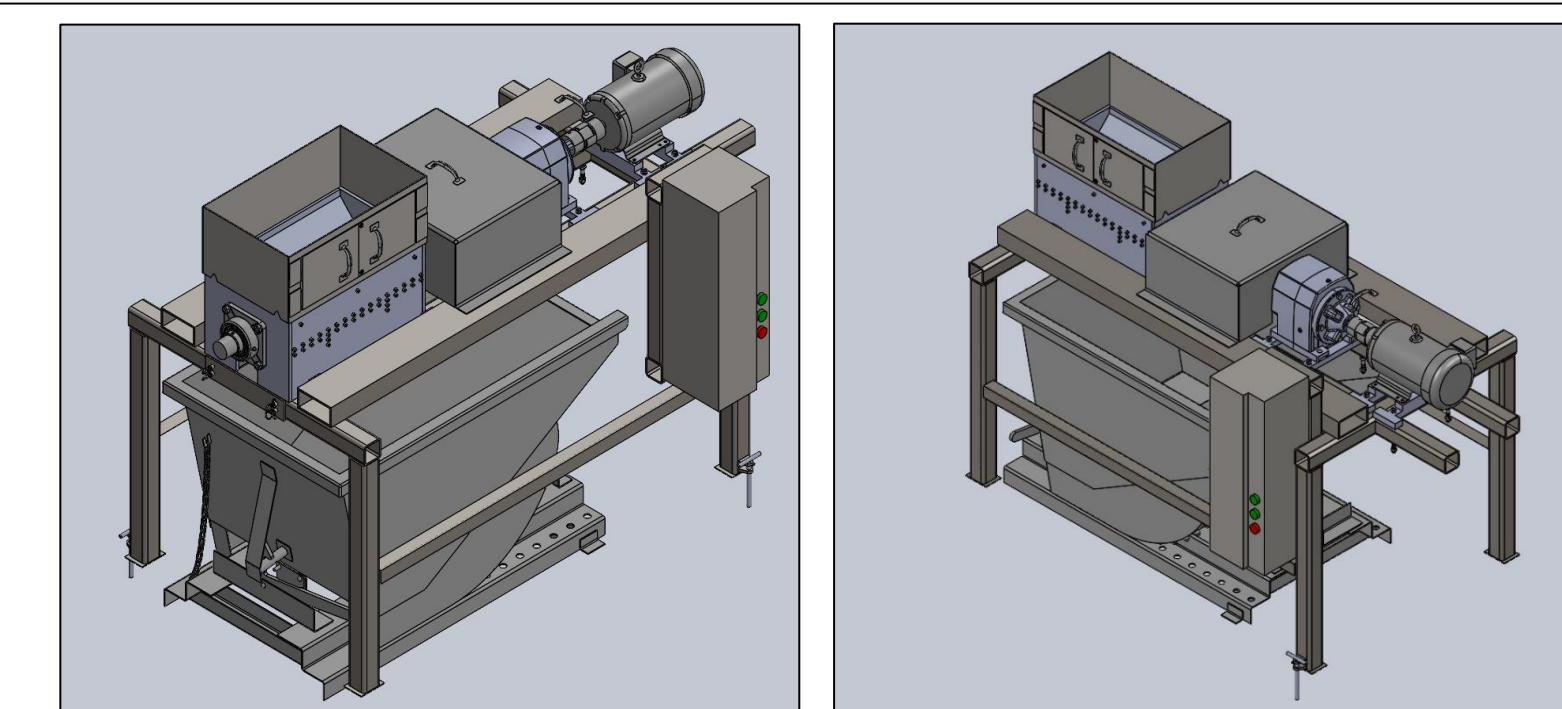

Figure 12a-b: Final CAD Models of the Shredder

CONCLUSION

Throughout the past year, the team was able to design and fabricate safety guarding for the shredder box and along the rest of the shaft, up to the standards set by Hendrickson's SOP 4.2. The team worked very closely with the sponsor to meet the expectations that had been set and to work from the frame constructed the previous year. Pictured in Figures 9 and 10 is the machine in its current and final state, with the safety guarding removed and in place. The torque limiter, gearbox, and motor are shown mounted to the frame.



Figure 13: Final Build w/o Safety Guarding



Figure 14: Final Build with Safety Guarding

LESSONS LEARNED

- Keeping open communication between all parties involved
- The planning phase of the design process is critical for all following phases.
- The importance, and difficulty, of concurrent engineering and how it can help a project like this.

ACKNOWLEDGEMENTS

George Hoger, Manufacturing Engineer II, Hendrickson
 Dave Warner, Maintenance Engineer, Hendrickson
 Jared Conley, Owner, Conley Welding Specialties
 Doug Weddelman, Owner, Wauseon Machine

